

# LOW PRESSURE REGULATOR FOR VERY HIGH FLOWRATE 7906



Art.7906

The application of this single-stage low pressure regulator is everywhere, where in spite of a low inlet pressure a very high flowrate is required. This is particularly the case in distribution pipelines from liquid tanks with subsequent vaporization. The main field of application of the low pressure regulator is as line regulator.

Even with a relatively small difference between inlet and outlet pressure, the regulator stands out by a very high flowrate up to 800 Nm<sup>3</sup>/h (for details see flow diagrams on the reverse side). Construction type single-stage diaphragm regulator with a very high pressure constancy.

Thanks to the compact design, the regulator is very robust and therewith not susceptible for breakdowns. The regulator is suited for all industrial gases and gas mixtures with exception of corrosive or poisonous gases, including oxygen. Ignition test for oxygen certified by BAM.

The working pressure of the low pressure regulator is adjustable up to 12 bar. The maximum inlet pressure is 50 bar.

## Technical specification :

Inlet pressure	:	max. 50 bar
Outlet pressure	:	0 – 12 bar
Maximum flowrate	:	800 Nm <sup>3</sup> /h (see flow diagrams)
Gases	:	all gases and gas mixtures except corrosive or poisonous gases
Inlet	:	G1" inner thread
Outlet	:	G1" inner thread (as option with nipple G1" outer thread)
Material	:	body brass, diaphragm EPDM, sealing material EPDM/FPM/PA6/POM, filter made of inox wire mesh 1.4401
Operating temperatures	:	-20 up to + 60C°
Weight	:	3.3 kg

# GLOOR

**Flow diagrams :**  
Inlet pressure 50bar

p1 = 50bar / p2 = 12/10/8/6/4/2bar / gas compressed air

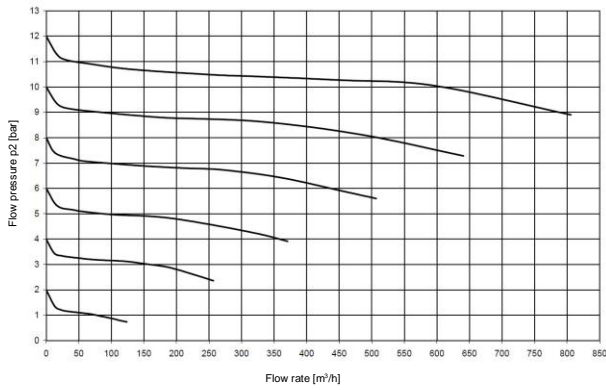

**Inlet pressure 40bar**

p1 = 40bar / p2 = 12/10/8/6/4/2bar / gas compressed air

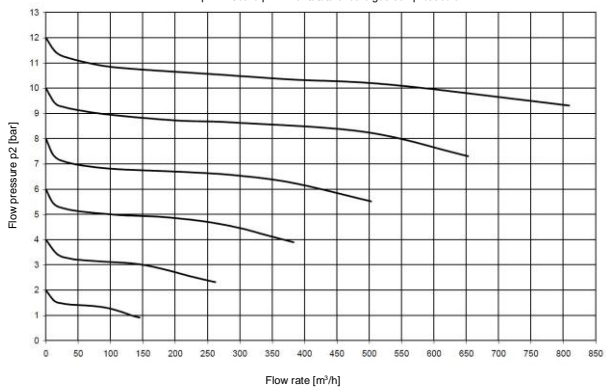

**Inlet pressure 25bar**

p1 = 25bar / p2 = 12/10/8/6/4/2bar / gas compressed air

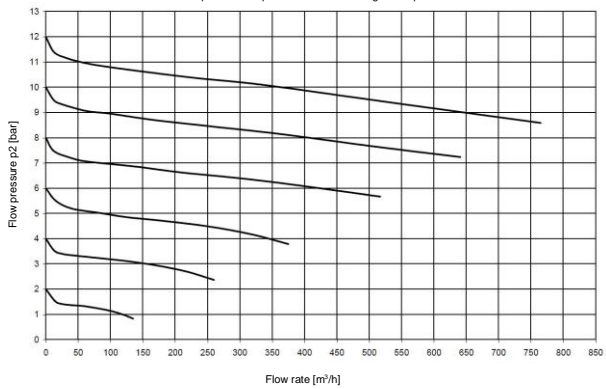

**Inlet pressure 15bar**

p1 = 15bar / p2 = 12/10/8/6/4/2bar / gas compressed air

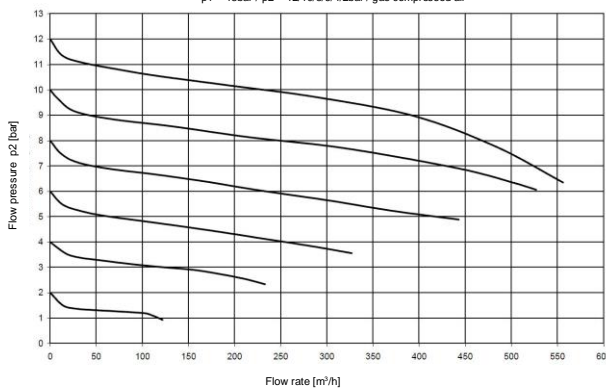

7906

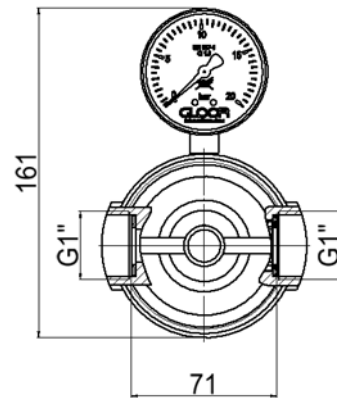

**Dimensions incl.nipple outer thread:**  
7906-AG

